

VERFAHREN ZUR HERSTELLUNG CONSTRUCTION METHOD

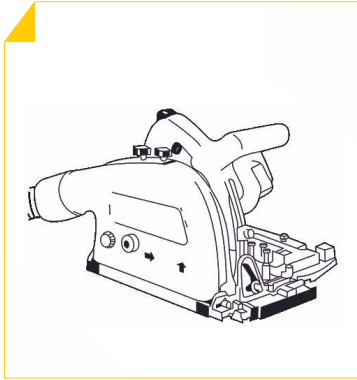

Plattenfräsmaschine
Sheet Milling Machine

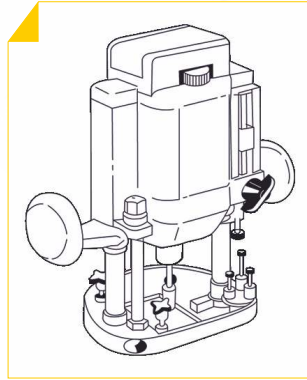

Manuelle Fräsmaschine
Hand Routing

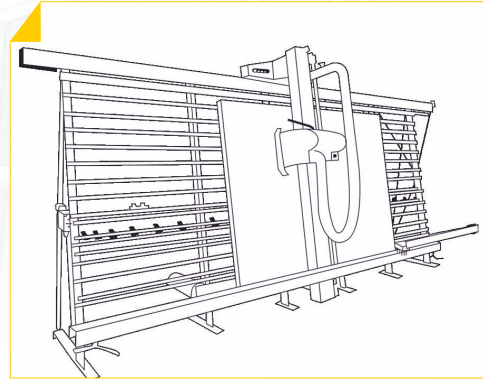

Plattensäge
Panel Saws

■ SCHÄLUNG DER RÜCKSEITE ■ BACK STRIPPING METHOD



Die Tiefe der Aluminiumschicht wird unter Hilfenahme eines Schneidmessers mit Maßen von 4- 6 cm definiert.

Portaying with an art designing knife deep into the aluminium layer on the rear of an ACP, arraying as the distance as 4-6cm.



Verwenden Sie zum Hobeln der vertikalen Oberflächenkanten mit 5 x 1,5 cm ein Elektrohobel

Using electronic plane to plan 5 x 1.5 cm on the face of the ACP from the both-vertical edges.



Entfernen Sie den Aluminiumstreifen von der Verbundplatte, damit ist die Platte leichter zu biegen.

Peel off the aluminium layer of the ACP, and then the panel become little bending.

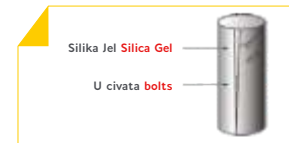

Biegen Sie die Platte, dann mit U-Bolzen festlegen und anschließend die Fugen mit Silikongel füllen.

Bending the panel, then using the U bolts fix the panel on the column, and then use silica gel fill up the seam.

WERKZEUGE TOOLS



Bohrtisch
(Bohrmaschine)
Churn Drill
(Electrical drill)



Tragbarer Schneider
Portable Cutter



Schleifmaschine
Portable Grinder



Bohrmaschine
Pistol Drill



Nagelzange
Nail Puller